

5 x 7 DOTS

DATA SHEET

- ❖ Scrolling Arrow.
- ❖ Static Arrow.
- ❖ Active high or Active low inputs.

Description

The DSARR is a single dot matrix arrow direction indicator for elevators. It is designed to display arrows on landings. The DSARR is a microcomputer-controlled unit, which allows high flexibility. The display arrow can be configured to be static or scrolling and several different arrow modes are available as specified in the display option table.

The DSARR has a dipswitch on the PCB board with which to select the different modes of operation. (Please refer to the display option table.)

The dot matrix comes only in red.

Wire connection to DSARR:

- DI Down direction, active low or active high input, dependant upon software version and user requirements.
- UI Up direction, active low or active high inputs, dependant upon software version and user requirements.
- FI Control input for managing the different display capabilities. (Please refer to display option data sheet.) FL was originally designed to start arrow flashing when FL=GND (active low).

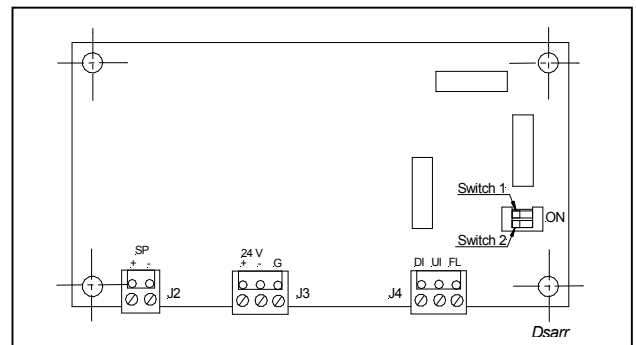
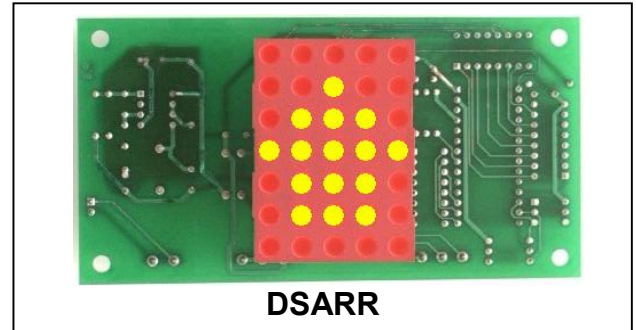

Display Options#

Switch 1	Switch 2	Description
OFF *	ON *	Static arrow when UI/DI = GND and FL = GND. When both UI and DI = GND no arrow shows. (This is lantern mode.)
OFF	OFF	Static arrow when UI/DI = GND.
ON	OFF	Static arrow when UI/DI = GND. Arrow starts scrolling when FL= GND.
ON	ON	Scrolling arrow when UI/DI = GND and FL = GND.

* This is the setting at the factory.

Modes are programmed by handheld tool.

Bi-directional arrow shows always when both UI = GND and DI =GND except when in lantern mode.

Bi-directional

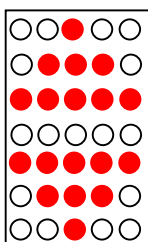

DN

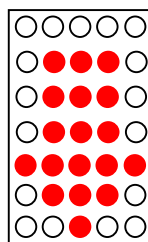

UP

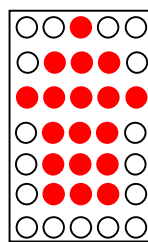

Go left

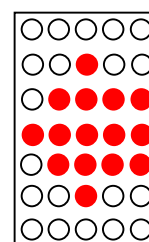

Go right

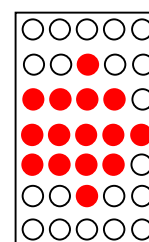

Specifications

Power supply	24 – 32V DC regulated, unfiltered.
Current consumption	80 mA max @ 24V DC.
Arrow control	3 wires, UI, DI, FL.
Display	Single dot matrix (5 x 7 dots) 53mm height.
Input threshold, all inputs	0V DC - 6V DC = "0" 6V DC - 24V DC = "1", High Impedance.
Weight	60 gr.

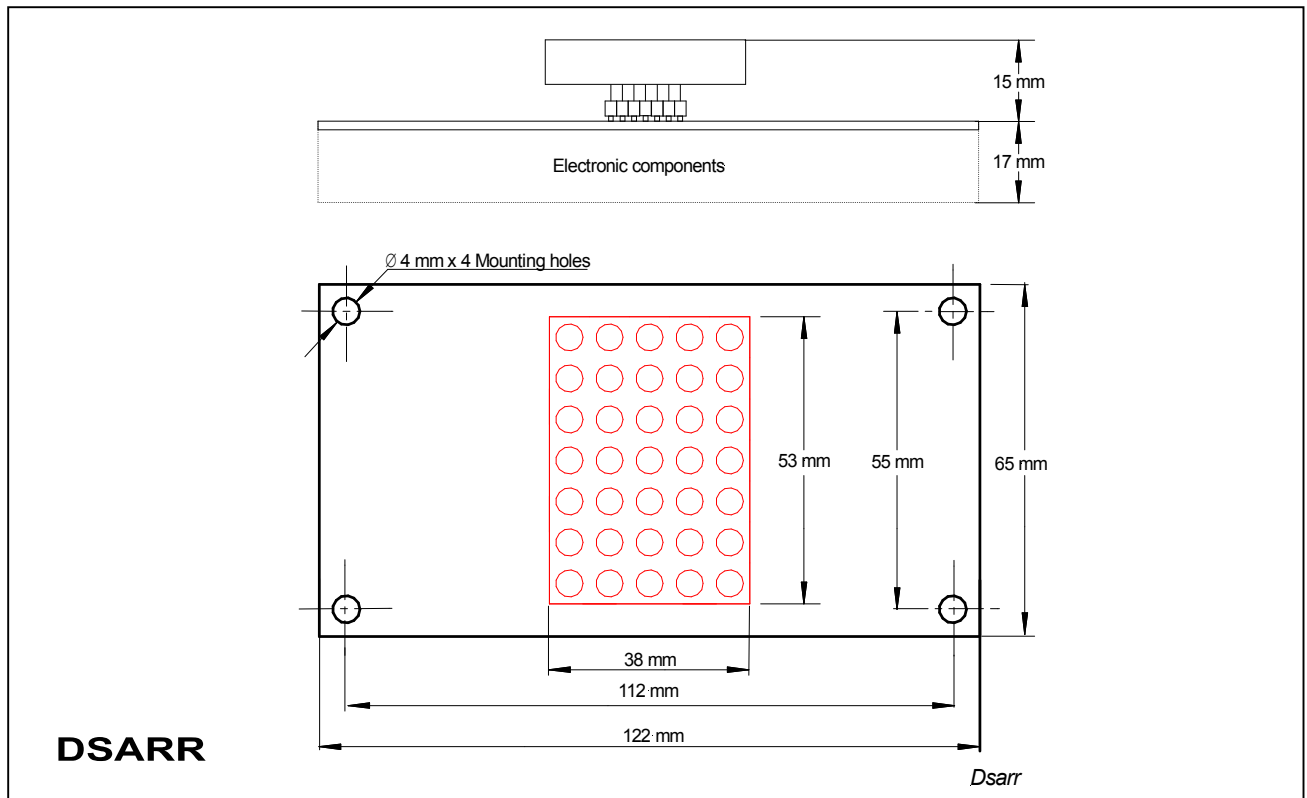
**Ordering Information**

DSARR	122mm x 65mm PCB.
-------	-------------------