

DATA SHEET

- 70 direct and cross beams
- External control box
- Supply voltage 230 V AC, 110V AC, 24 V DC
- Relay output, both N.O. and N.C. are available to user (changeover).
- Digital diagnostics.
- Slim and wide housings available.

Description

The SAR70 is used to protect passengers in elevators equipped with automatic doors. This protection is achieved by **70 DISCRETE INFRARED BEAMS**, which are transmitted and received between two edges. When one or more beams are obstructed the buzzer is activated and the relay is de-energised. The output relay is a one-changeover relay with N.O. and N.C. contacts both available to the user.

The major system components are a transmitting edge, "TX", a receiving edge, "RX", and a control box. The edges are mounted to the car doors or strike posts and the control box is mounted to the car top. Each edge is connected to the control box via a 4.5 m edge cable. The system is fail-safe, i.e. the output relay will de-energise if either of the following occurs:

1. System power is lost.
2. Edge cable is damaged.

Control box

Three models of control box are available:

- ❖ Model **C2**: LED diagnostics display
- ❖ Model **C3**: Digital readouts (7-segment display), 24VDC/110VAC/230VAC **factory set**
- ❖ Model **C5**: Digital readouts (7-segment display), 110VAC/230VAC **user selectable**

Housing

Aluminium housings available for SAR70 are:

- ❖ Model **S**: Slim extrusion of housing (see fig. 7)
- ❖ Model **W**: Wide extrusion of housing (see fig. 8)

Faulty beam cancellation

Faulty beam cancellation can be enabled or disabled by the beam cancellation switch on control box PCB (refer to fig. 3 & fig. 5 for location).

If the system senses an obstruction of one beam for a period of one minute it will designate the beam as faulty and cancel that beam whereupon normal door operation will resume. The system will continue to operate normally until three successive beams are designated as faulty. If the system senses that a faulty beam is restored then after one minute it will countermand the cancellation and the beam will come back into operation.

If this feature is disabled and the system senses an obstruction then the doors will remain open indefinitely.

The bottom and top beams are not cancelled by the system. If one of these beams becomes faulty the doors will remain open indefinitely.

Audible Buzzer

The buzzer, if enabled, will sound when the system senses an obstructed beam.

The buzzer can be enabled or disabled by setting the buzzer switch on control box PCB (refer to fig. 1, fig. 3 & fig 5 for location).

Auto check

The SAR70 has a unique feature that allows the elevator controller to check the SAR70 and it's wiring prior to each door closing. This eliminates the risk of door closure while the output relay of the detector is trapped or welded, or the wiring is short-circuited. Trapped or welded output relay, or short-circuited wiring, are very risky and could lead to door accidents.

This feature is activated through "TEST" input on control box PCB (refer to fig. 1 & fig. 3 & fig. 5).

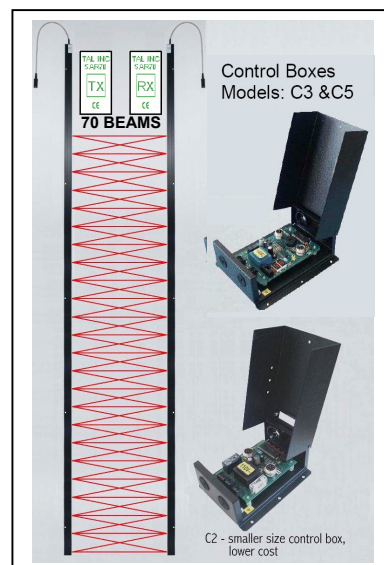

Control Box for Model: C2



Control Box for Model: C3

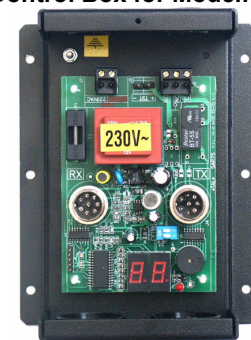

Control Box for Model: C5

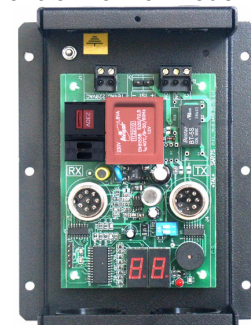

THREE MODELS OF CONTROL BOX

Model C2

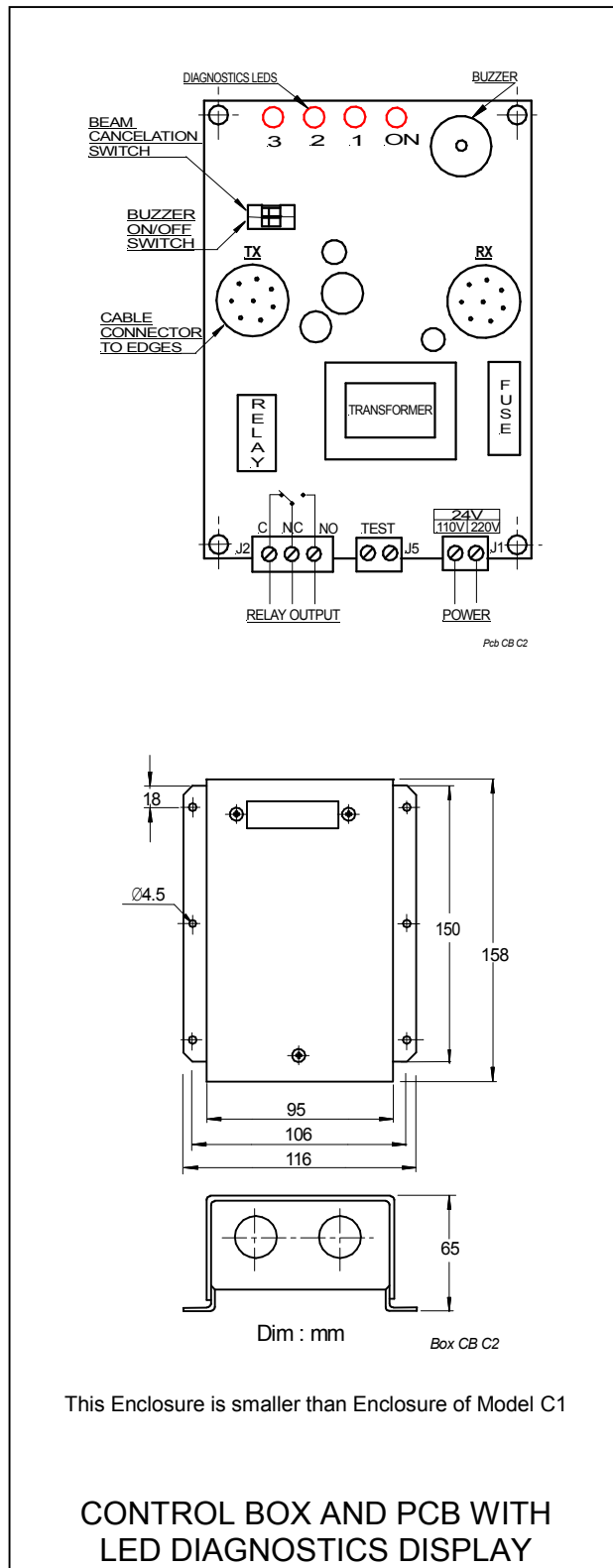

Fig. 1

Model C3

Control Box with Digital Diagnostics Display, 230VAC or 110VAC, Factory Set

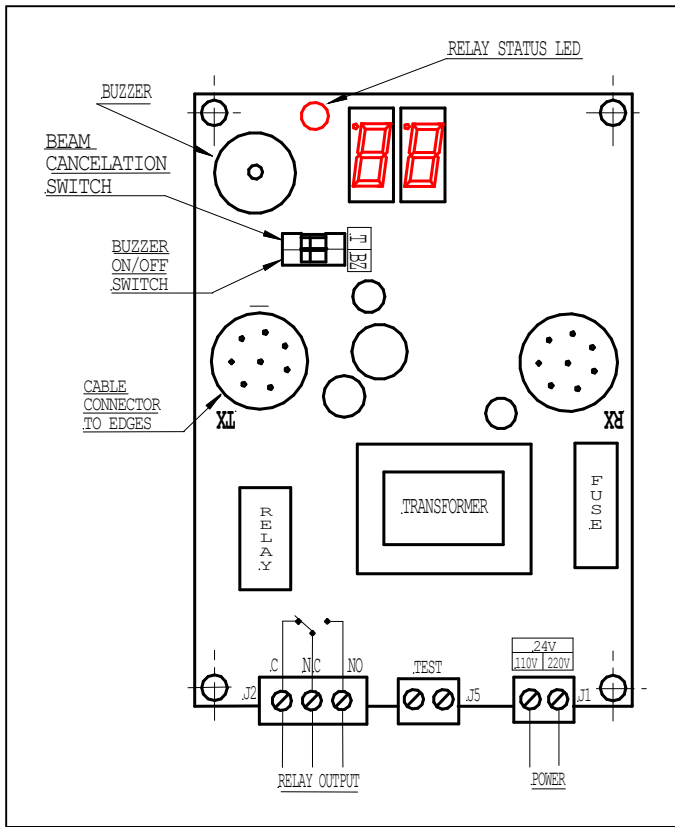

Fig. 3

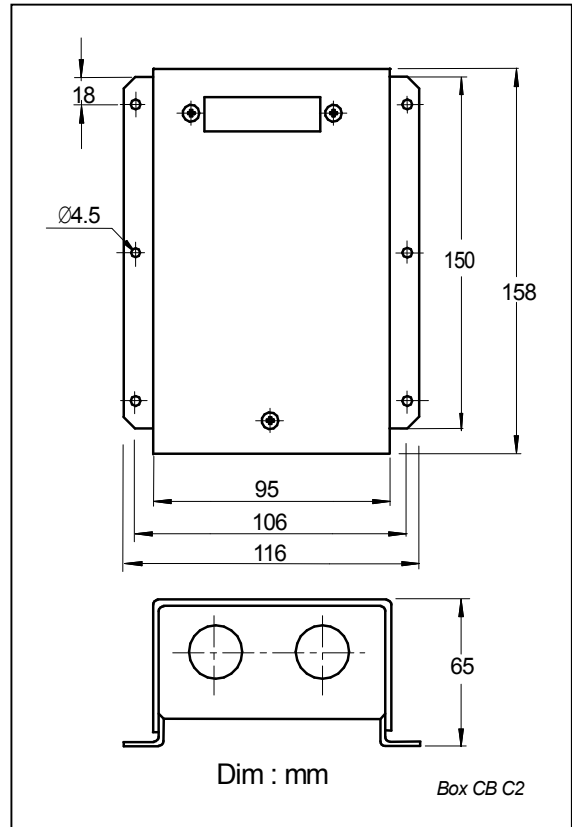

Fig. 4

Model C5

Control Box with Digital Diagnostics Display and Voltage Select Switch 230VAC / 110VAC, User Selectable

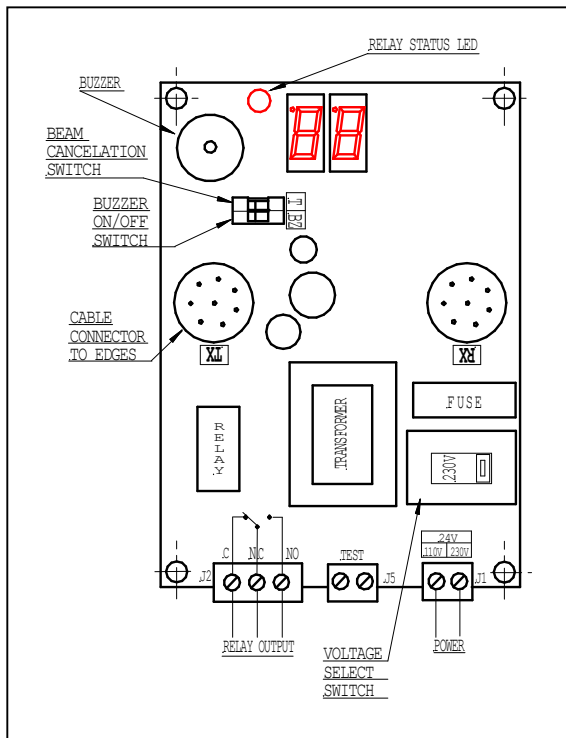

Fig. 5

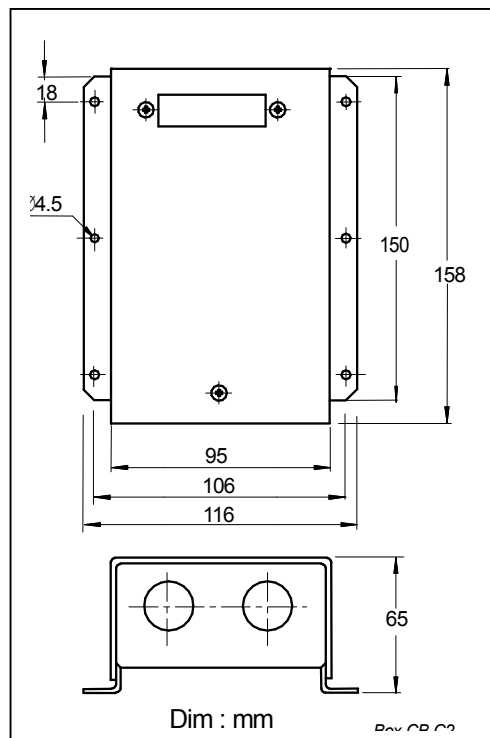

Fig. 6

DIAGNOSTICS CODES**Control Box Model C2**

| LED | Description | Cause |
|------------|--|---|
| ON | This LED normally flashes when power is applied. | |
| 1 | LED "ON" – no active beam is obstructed. System is ready for detection. | |
| 2 | LED "ON" – there is a general fault problem. System is not operating. | General fault or cable fault. |
| | LED flashes slowly – there are some cancelled faulty IR diodes on TX edge. | Less than three non-consecutive IR diodes are faulty. |
| | LED flashes at a high rate - there are too many faulty IR diodes on TX edge. System cannot cancel more beams. System is not operating. | More than three IR diodes are faulty. |
| 3 | LED "ON" – there is a general fault problem. System is not operating. | General fault or cable fault. |
| | LED flashes slowly - there are some cancelled faulty IR receiving diodes on RX edge. | Less than three non-consecutive IR receiving diodes are faulty. |
| | LED flashes at a high rate - there are too many faulty IR receiving diodes on RX edge. System cannot cancel more beams. System is not operating. | More than three IR receiving diodes are faulty. |

Control Boxes Models: C3 & C5

LEFT DIGIT CORRESPONDS TO TX EDGE DIAGNOSTICS.
RIGHT DIGIT CORRESPONDS TO RX EDGE DIAGNOSTICS.

| Display Code | Description | Cause | Corrective Action |
|------------------------|---|--|---|
| X1 | One RX IR detector has timed out. | Faulty IR detector. | None. |
| X2 | Two RX IR detectors have timed out. | Two faulty IR detectors. | None. |
| X3 | Three RX IR detectors have timed out. | Three faulty IR detectors. | The SAR76 will continue to operate at this point, however, one more IR detector failure will cause the SAR76 to fail-safe. We recommend installing a new RX edge at this time thus avoiding the elevator becoming out of service. |
| 1X | One TX IR LED has timed out. | Faulty IR LED. | None. |
| 2X | Two TX IR LEDs have timed out. | Two faulty IR LEDs. | None. |
| 3X | Three TX IR LEDs have timed out. | Three faulty IR LEDs | The SAR76 will continue to operate at this point, however, one more IR LED failure will cause the SAR76 to fail-safe. We recommend installing a new TX edge at this time thus avoiding the elevator becoming out of service. |
| JA | General fault. System is not responding. | Electronic component within TX edge, more than 8 IR LEDs are faulty or cable fault. | a) Check cables. b) Replace TX edge. |
| AJ | General fault. System is not responding. | Electronic component within RX edge, more than 8 IR detectors are faulty or cable fault. | a) Check cables. b) Replace RX edge. |
| JJ | General fault within TX edge and RX edge. System is not responding. | Electronic components within RX and TX edges, more than 8 IR LEDs and detectors are faulty or cable fault. | a) Check cables. b) Replace system. |
| FX | Top IR LED has timed out. System is not responding. | a) IR LED obstructed by foreign object. b) Faulty IR LED. | a) Check for possible obstructions. b) Replace TX edge. |
| XF | Top IR detector has timed out. System is not responding. | a) IR detector obstructed by foreign object b) Faulty IR detector. | a) Check for possible obstructions. b) Replace RX edge. |
| LX | Bottom IR LED has timed out. System is not responding. | a) IR LED obstructed by foreign object b) Faulty IR LED. | a) Check for possible obstructions. b) Replace TX edge. |
| X = Don't care. | | | |

| Display Code | Description | Cause | Corrective Action |
|----------------------|---|--|--|
| A_X | More than three IR LEDs (not necessarily consecutive) have timed out. System is not responding. | a) Obstructed IR LEDs. b) Faulty IR LED. | a) Check for possible obstructions. b) Replace RX edge. |
| x_A | More than three IR detectors(not necessarily consecutive) have timed out. System is not responding. | a) Obstructed IR detectors. b) Faulty IR detector. | a) Check for possible obstructions. b) Replace TX edge. |
| CC | More than three IR devices (LEDs or detectors) have timed out. System is not responding. | a) Edges have become soiled. b) Faulty devices (LEDs or detectors). | a) Clean edges. b) Replace RX and TX edges. |
| EE | Corresponding IR LED and IR detector Have timed out. System is not responding. | Faulty IR LED on TX edge and faulty IR detector on RX edge. | Replace RX and TX edges. |
| H_X | Two consecutive IR LEDs have timed out. System is not responding. | Faulty LEDs on TX edge. | Replace TX edge. |
| x_H | Two consecutive IR detectors have timed out. System is not responding. | Faulty IR detectors on RX edge. | Replace RX edge. |
| x_U | More than three IR detectors have timed out. System is not responding. | Faulty (shorted) IR detectors on RX edge, type of fault is internal short circuit. Note: This case differs from x_A by type of fault. In x_A IR detector does not respond, in x_U IR detector responds continuously (shorted). | Replace RX edge. |

X = Don't care.

TWO MODELS OF HOUSING

Model S

Model W

SLIM HOUSING

WIDE HOUSING

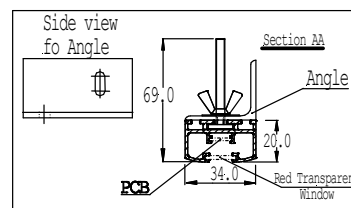
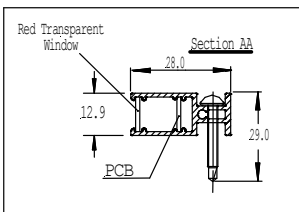
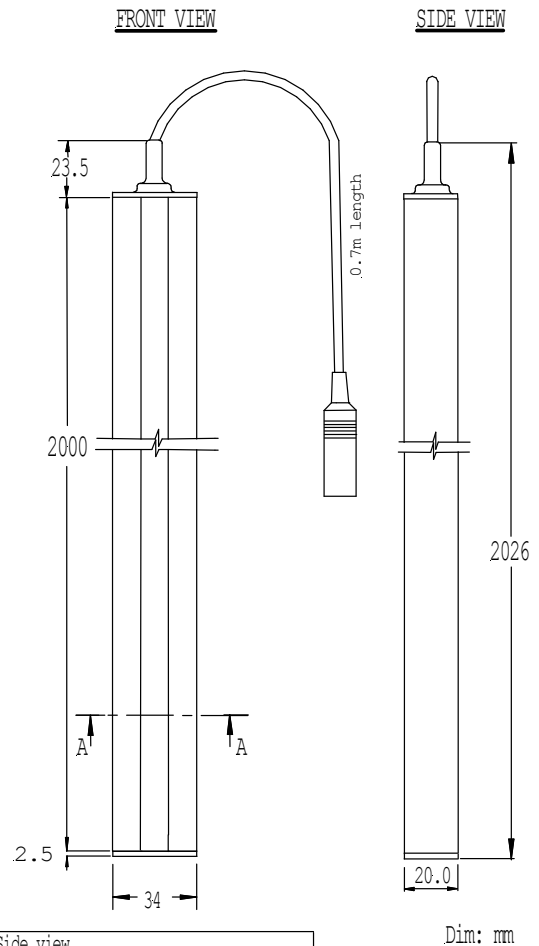
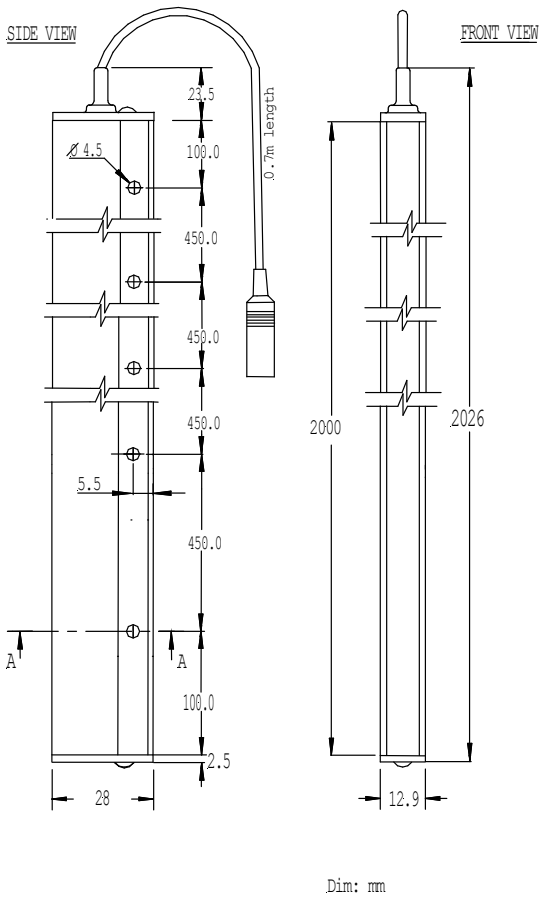
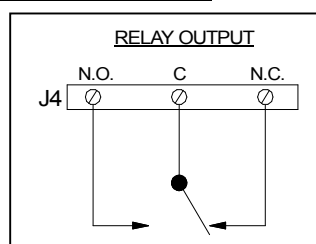

Fig. 7

Fig. 8

ATTENTION! Inductive load.**Relay Output**

When the output relay drives an inductive load (contactor, relay, etc.) arc suppression means should be taken. Use varistor, diode or RC network according to nature of load and its power supply.

Specifications

| | |
|--------------------------|---|
| Supply Voltage | 24V AC/DC or 110V AC or 230V AC Factory Set. |
| Power Consumption | 4VA max. |
| Output | Relay, dry contact, N.O./ N.C. 1A @ 125V (one Changeover). The relay is energised during operation when no beam is interrupted. |
| Range | min.: 0m max.: 4.5m |
| Edge height | 2000mm (78.75") |
| Highest beam height | 1661mm (65.4") |
| Lowest beam height | 25.4mm (1") |
| Total no. of beams | 70 (Not dependent on the door opening.) |
| No. of direct beams | 24 |
| Grid distance | 71.2mm (2.8") for direct beams only, together with crossing beams grid is much more dense. |
| Buzzer | 3Khz Can be switched off. |
| Faulty Beam Cancellation | Enable/disable by dipswitch. On controller board up to three successive beams can be cancelled. |
| Indicators | LED, to indicate that no beam is obstructed. |
| Faulty beams indicators | Two-digit display, a beam is declared as faulty after one minute of not responding. |
| Cable | Flexi, 8 x 0.14 |
| Cable length | 4.5m each (14.76 ft) |
| Mounting arrangements | Five holes of 4.5mm diameter for slim version. Sliding bolt for wide version. |
| Edge case material | Aluminium, black anodized. |
| Packed weight | 4.6 Kg (10 Lbs) |
| Ambient temp. | -10° C to 50° C |
| Controller sealing | IP 20 |
| Edges sealing | IP 51 |
| Ambient light | Full sunlight (40 Klux), full dark. |
| External text | Special input ("TEST") for testing unit by elevator computer. |
| Approvals | CE |

Beam Location

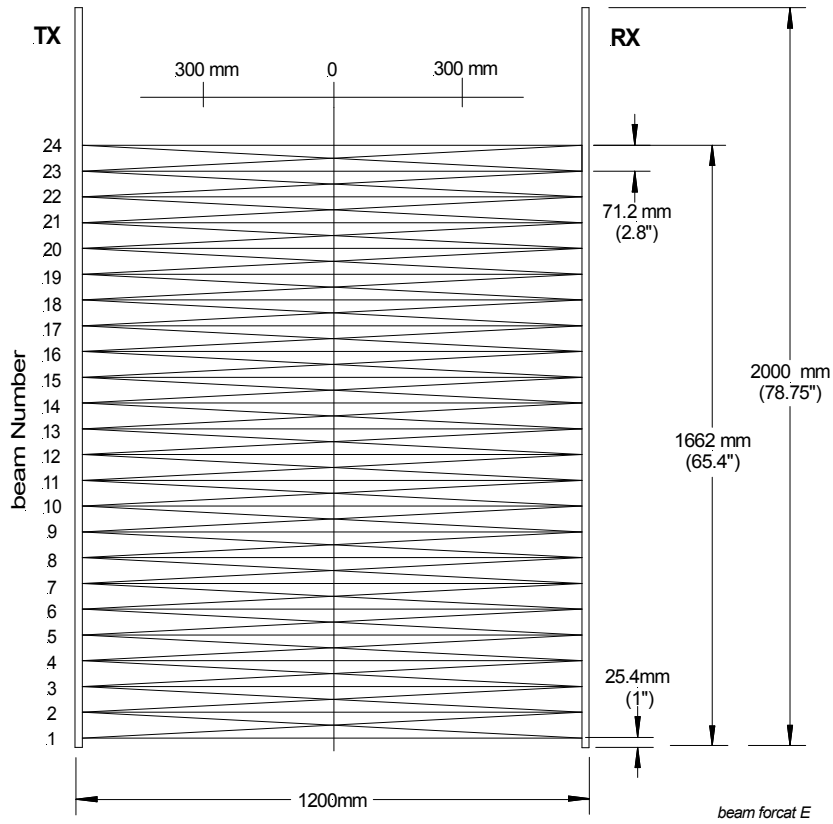

Cable Details

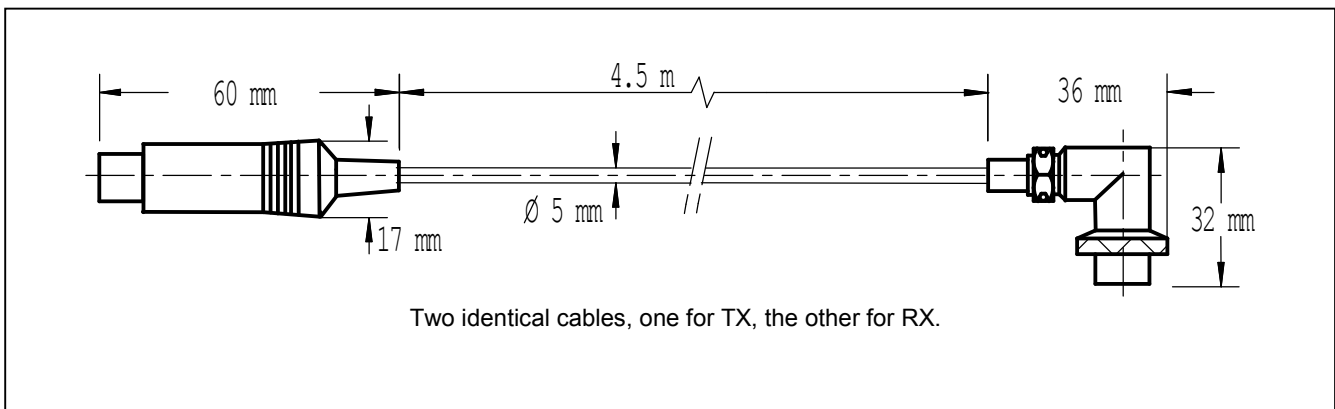

Mounting Hardware

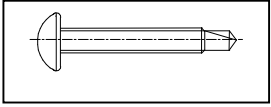
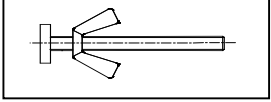
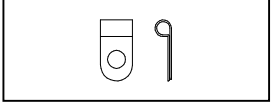
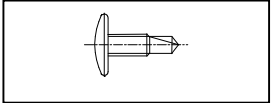
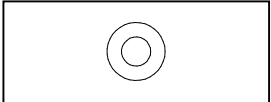
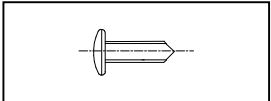
| | | |
|--|-----|--|
| Self-drilling screws 8x1" included in the set. Only for model SAR70 -S (slim housing). | 10x |  |
| Square headed bolts, Wing nuts, Washers & Spring washers included in the set. Only for model SAR70-W (wide housing). | 4x |  |
| P-clips: p-clips 3/16" (cable holders). | 6x |  |
| Self-drilling, wide-headed screws. | 6x |  |
| Washers. | 6x |  |
| Sheet metal screws. | 6x |  |

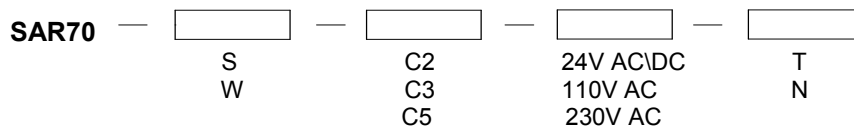
Ordering information

- | | |
|----|--|
| S | = Slim housing. |
| W | = Wide housing. |
| C2 | = LED diagnostic display control box. |
| C3 | = Digital readouts factory set voltage. |
| C5 | = Digital readouts user selectable voltage. |
| T | = Tubular carton 2.1 m length x 50 mm in diameter. |
| N | = Transparent polyethylene sleeve. |

Example for Ordering.

| Part No. | Description |
|----------------|--|
| SAR70-S-C2-24 | SLIM housing, C2 type control box, 24V AC supply. |
| SAR70-W-C2-24 | WIDE housing, C2 type control box, 24V AC supply. |
| SAR70-S-C2-110 | SLIM housing, C2 type control box, 110V AC supply. |
| SAR70-W-C2-110 | WIDE housing, C2 type control box, 110V AC supply. |
| SAR70-S-C2-230 | SLIM housing, C2 type control box, 230V AC supply. |
| SAR70-W-C2-230 | WIDE housing, C2 type control box, 230V AC supply. |
| SAR70-S-C3-24 | SLIM housing, C3 type control box, 24V DC supply. |
| SAR70-W-C3-24 | WIDE housing, C3 type control box, 24V DC supply. |
| SAR70-S-C3-110 | SLIM housing, C3 type control box, 110V AC supply. |
| SAR70-W-C3-110 | WIDE housing, C3 type control box, 110V AC supply. |
| SAR70-S-C3-230 | SLIM housing, C3 type control box, 230V AC supply. |
| SAR70-W-C3-230 | WIDE housing, C3 type control box, 230V AC supply. |
| SAR70-S-C5 | SLIM housing, C5 type control box, 230V / 110VAC supply. |
| SAR70-W-C5 | WIDE housing, C5 type control box, 230V / 110VAC supply. |

Packing Information

Each set of edges can be packed in either of the following ways:

1. T = Tubular carton 2.1m length x 50 mm in diameter.
N = Transparent polyethylene sleeve.
2. The control box is packed in a 250 mm x 220 mm x 110 mm height, carton.

Limitations

The SAR70 light curtains will not detect the following objects:

- a. Transparent objects.
- b. Chains, ropes, ribbons and other similar objects with a small cross-section.
- c. Small or thin objects.

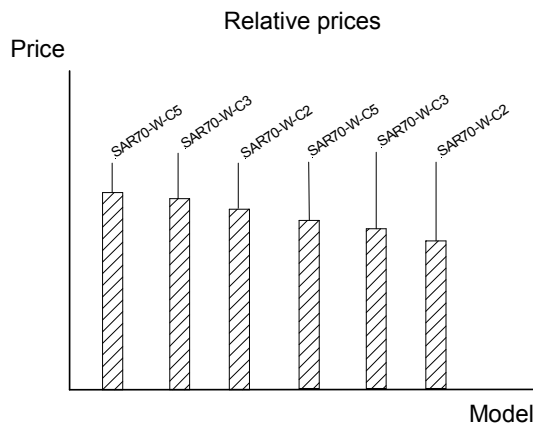
Prices

Note: Product with N package type has a lower price than T package type.

WARNING

SAR70 light curtain is not a safety system and must not be used as such.
SAR70 is not designed for personnel safety, and must not be used as a stand-alone personnel safety system.
SAR70 light curtain is for elevator use only.