

DATA SHEET

- 70 beams
- 24 V DC or (110V AC / 220V AC with optional Control box)
- Relay output, both N.O. and N.C. are available to user (Change over)
- Diagnostics LEDs
- Slim and wide housing available.

Description

The SAR70EL is used to protect the entrances of elevators equipped with automatic doors. Protection is achieved by **70 DISCRETE INFRARED BEAMS**, which are transmitted and received between two edges, a transmitting edge "TX" and a receiving edge "RX". When one or more beams are obstructed an output relay, located on RX edge, is de-energized and the left LED on RX edge (see fig. : 1) is extinguished. The output relay is a change over relay with N.O. and N.C. contacts, of which **both are available to user**.

The edges are mounted to the car doors or strike post. Each edge is equipped with a pluggable 4.5 m cable. The system is fail-safe i.e. the output relay will de-energize if any of the following occurs:

1. System power is lost.
2. Edge cable is damaged.

Housing

Aluminium housings available for SAR70EL are:

- ❖ Model **S** : Slim extrusion of housing (see fig. 3)
- ❖ Model **W** : Wide extrusion of housing (see fig. 4)

Faulty beam cancellation

Faulty beam cancellation can be enabled or disabled by connecting or disconnecting a cable wire on TX edge to +24V, refer to fig. : 5 & 6 for location.

If the system senses an obstruction of one beam for a period of one minute, it will designate the beam as faulty and cancel that beam. Where upon normal door operation will resume and system will continue to operate normally until three successive beams are designated as faulty. If the system senses that a faulty beam is restored it will after one minute null out the cancellation and the beam will be back in operation.

If this feature is disabled and the system senses an obstruction, the doors will remain open indefinitely.

The bottom and top beams are not cancelled by the system, when one of these beams becomes faulty the doors will remain open indefinitely.

The faulty beam cancellation can be enabled or disabled by connecting or disconnecting the Pink cable wire of TX to +24V.

Diagnostics

For diagnostics and trouble shooting there are two LEDs on RX edge and one LED on TX edge. These LEDs signalize to the user, by diagnostics codes, the status of the system. refer to fig. : 1 & 2.

External Control Box

For operation on voltages other than 24V DC such as 110V AC or 230V AC or when output relay rating on edges is too small, an external control box should be used (refer to fig. 7). This external control box contains a transformer, a buzzer, a 10A one changeover relay and a beam cancellation enable/disable switch.

This external control box is an option and should be ordered separately.

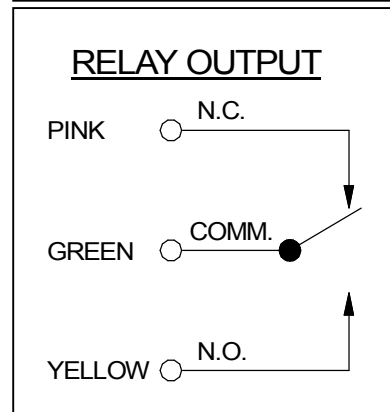
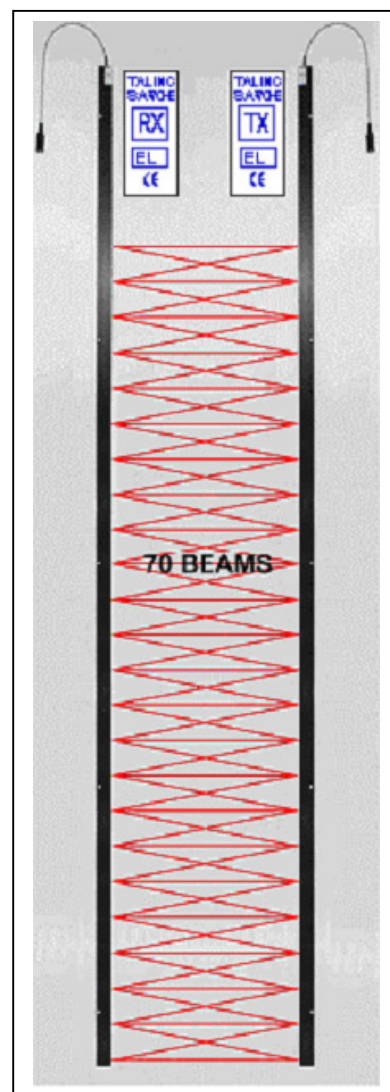

DIAGNOSTICS LEDs

DIAGNOSTICS CODES

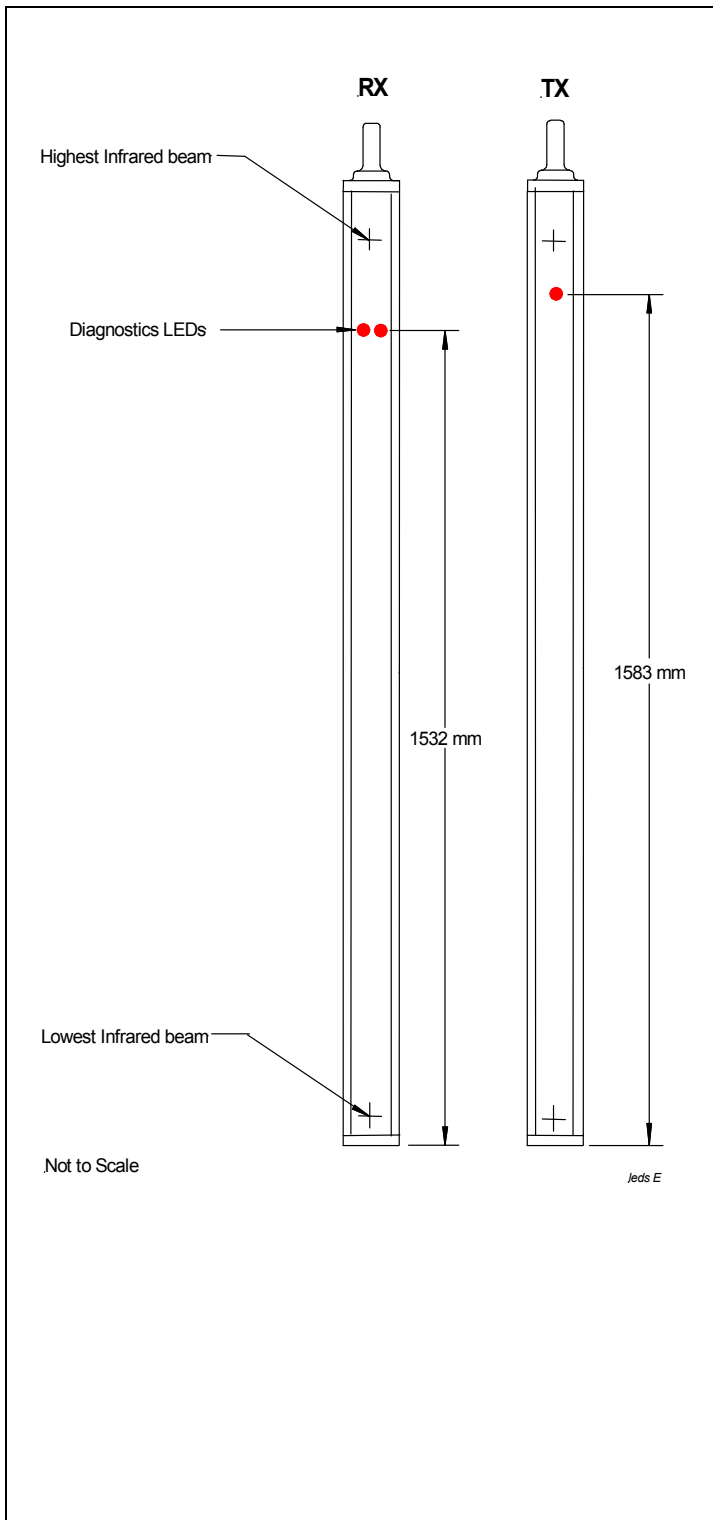

Fig No: 1

	LED	Description
TX	Single LED 	When "ON" power to the system is applied and Micro computer on TX edge is functioning properly.
		When left and right LEDs are "ON": No beam is obstructed system is operating.
RX		When left LED is "OFF" and right LED is "ON" : One or more beams are obstructed.
		When right LED is flashing slowly : There is one cancelled IR diodes on TX edge.
		When right LED is flashing fast: There are more than one cancelled IR diodes on TX edge not possible to cancel more IR diodes. Replacement of TX edge is required.
		When left LED is flashing slowly : There is one cancelled receiving diodes on RX edge.
		When left LED is flashing fast : There are more than one cancelled receiving diodes on RX edge not possible to cancel more receiving diodes. Replacement of RX edge is required.
		When left and right LEDs are flashing alternately: The synchronization signal between TX edge and RX edge is lost.
X = Don't care		= Flashing LED

Fig No: 2

TWO MODELS OF HOUSING

Model S

Model W

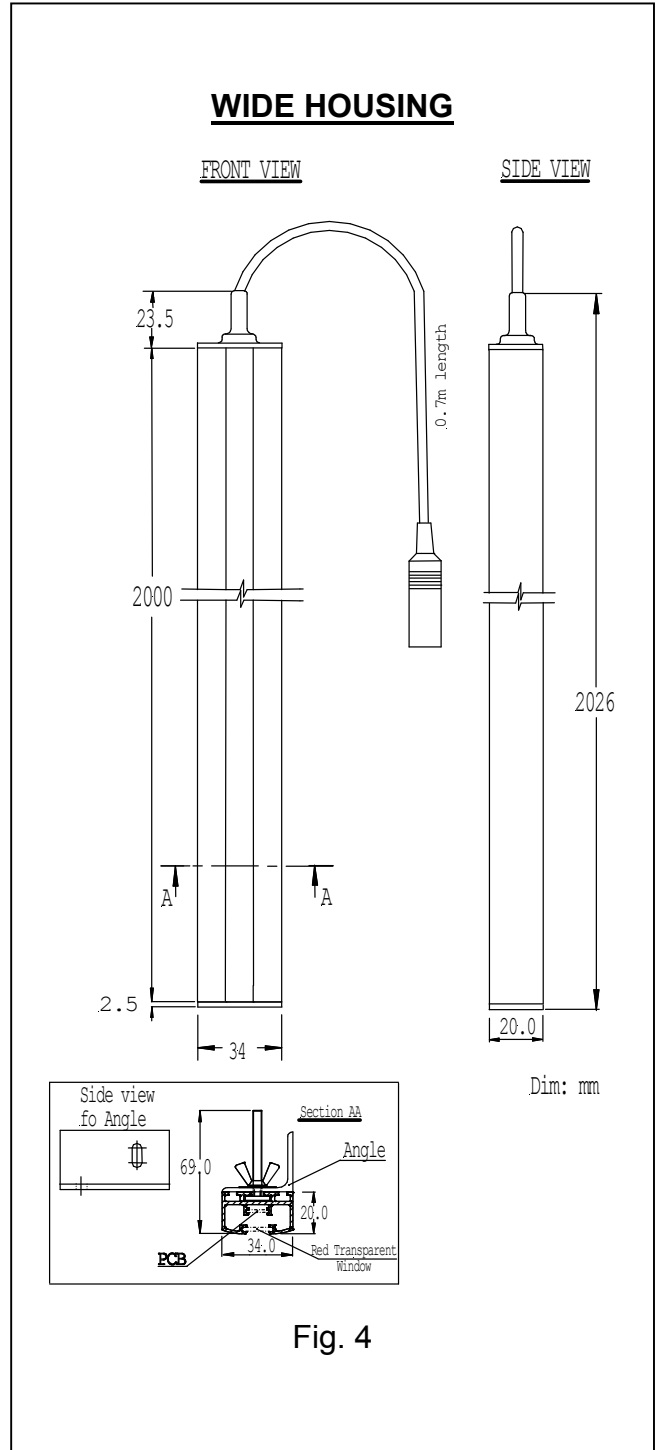
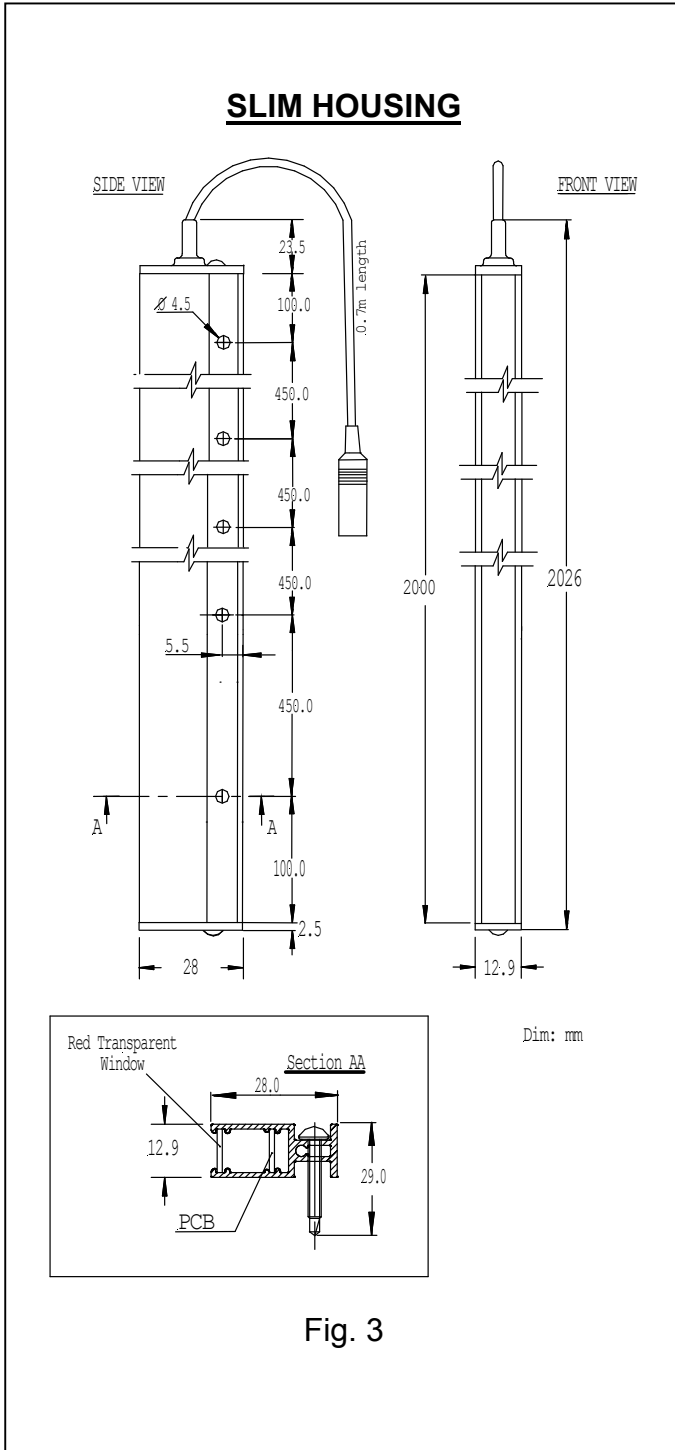

Output relay details

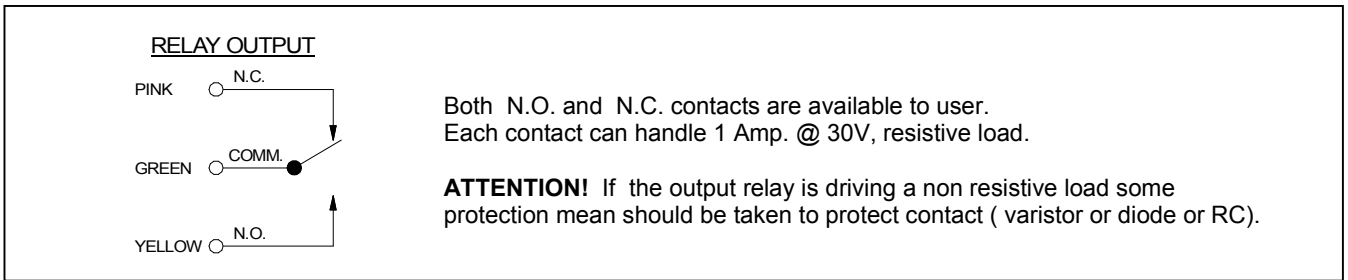

Cable Details

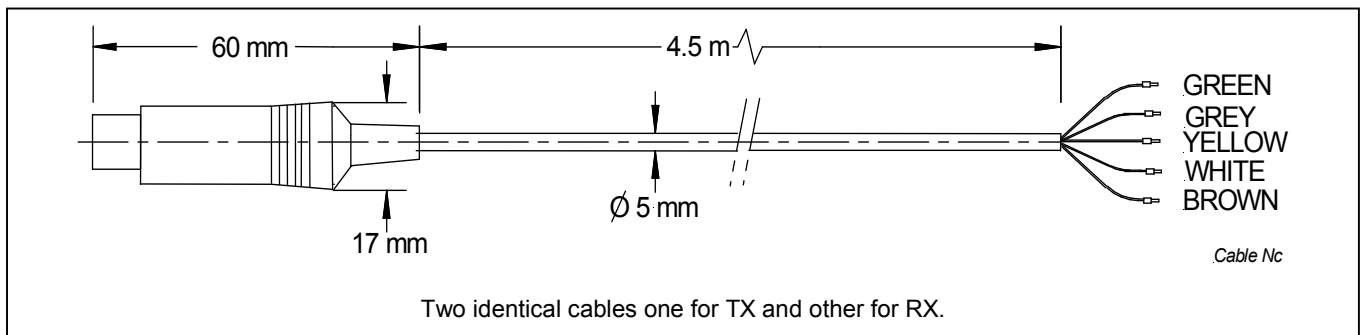

WIRE ASSIGNMENT

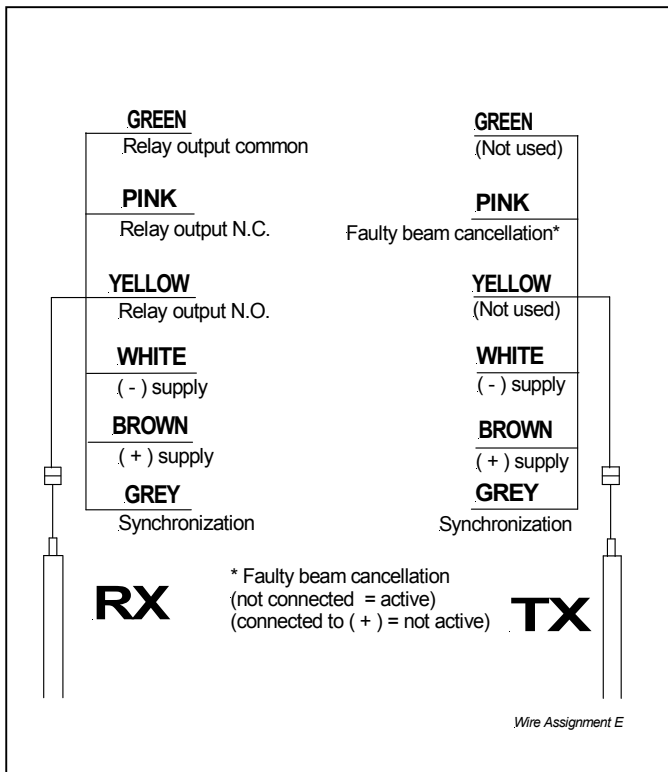

Fig No: 5

CONNECTION DIAGRAM

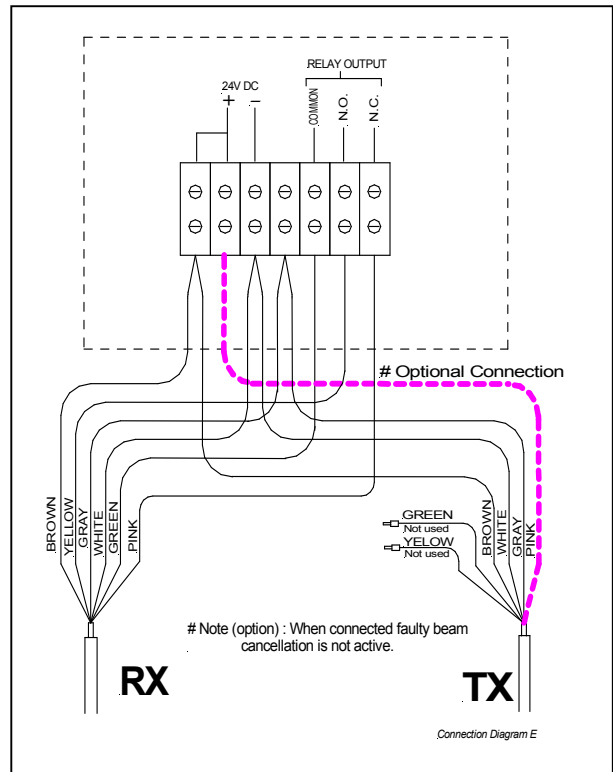

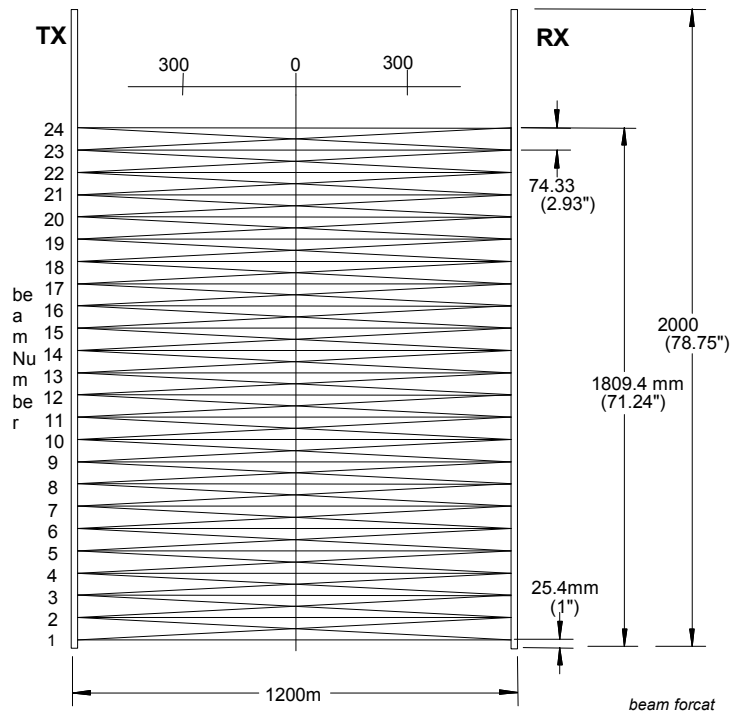

Fig No: 6

Specifications

Supply voltage	24V DCm (rectified unfiltered) or (110V AC / 230V AC by use of external control box (model: C4).)
Power consumption	4VA max
Output	Relay, dry contact, N.O. and N.C. 1A @ 30V, both contacts are available to user. The relay is energized during operation when no beam is interrupted. Booster relay of 10A one changeover is available by use of external control box (model: C4).
 Output relay information	Output relay is specified for 5×10^9 operations at 1A, 30VDC resistive load only, user shall not exceed these specification! Operation at 0.1A or less will increase expected No. of operations
Range	min.: 0m max.: 4.5m
Edge height	2000mm (78.75")
Highest beam height	1809.4mm (71.24")
Lowest beam height	25.4mm (1")
Total no. of beams	70 (Not dependent on the door opening)
No. of direct beams	24
Grid distance	74.33mm (2.93")
Faulty Beam Cancellation	Enable by disconnecting TX pink wire cable from 24V, disable by connecting TX pink wire, to 24V (or by dip switch on optional control box C4). Up to three non-successive beams can be cancelled.
Buzzer	Optional, on external control box.
Indicators	LED, for proper operation and diagnostics.
Faulty beams indicators	Two LEDs on RX edge, a beam is declared as faulty after one minute of not responding.
Cable	Flexi, 6 x 0.25
Cable length	4.5m each (14.76 ft)
Mounting arrangements	Five holes of 4.5 mm diameter for slim version. Sliding bolt for wide version.
Edge case material	Aluminum black anodized.
Packed weight	2.3 kgs.
Ambient temp.	-10°C to 50°C
Controller sealing	IP 20
Edges sealing	IP 51
Ambient light	Full sun light (40 Klux), full dark.
Approvals	CE

Beam Location

Control Box (option)

Optional Control Box Model: C4

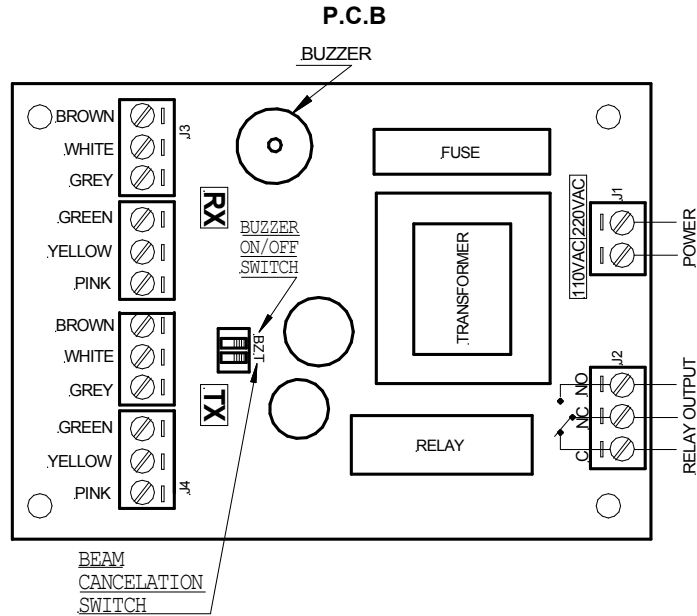

Metal Cover of the Control Box

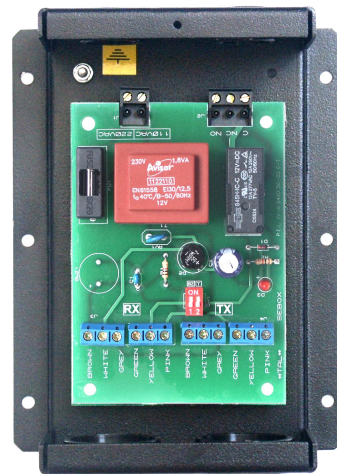
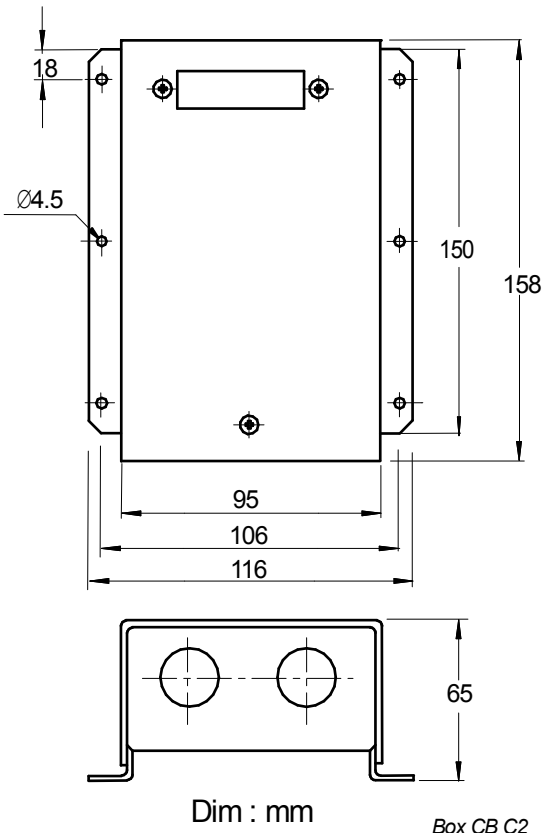

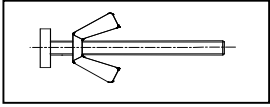
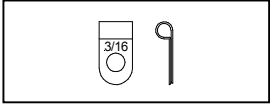
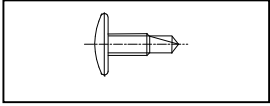
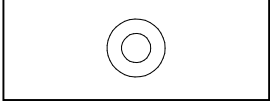
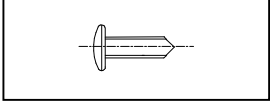

Fig No: 7

Mounting Hardware

Self drilling screws 8x1" included in the set. Only for model SAR70ELS (slim housing).	10x	
Square headed bolts, Wing nuts, Washers & Spring washers included in the set. Only for model SAR70ELW (wide housing).	4x	
P-clips : p-clips 3/16", as cable holders.	6x	
Self drilling wide headed screws.	6x	
Washers.	6x	
Sheet metal screws.	6x	

Ordering informationSAR70EL - 24VS = Slim housing
W = Wide housing**Example for ordering.**

Part No.	Description
SAR70ELS-24V	SAR70EL, SLIM housing
SAR70ELW-24V	SAR70EL, WIDE housing

Control box Ordering information (optional)SAR70E/EL - C4 -
110V
220V

SAR70E/EL - C4 - 110V	110V Operation Control box
SAR70E/EL - C4 - 220V	220V Operation Control box

Limitations and warnings

The SAR70EL light curtains will not detect the followings objects:

- Transparent objects.
- Chains, ropes, ribbons and similar objects with a small cross-section.
- Small or thin objects.

WARNING

SAR70-EL light curtain is not a safety system and must not be used as such.
SAR70-EL is not designed for personnel safety, and must not be used as a stand-alone personnel safety system.
SAR70-EL light curtain is for elevator use only.

Talino (UK) Ltd. Engineering reserves the right to change specifications without notice.

Talino en SAR SAR70EL DS v1.01 .doc