

### Model : ELCOM

#### DATA SHEET

- ❖ Two-way car to machine room communication
- ❖ Good sound clarity
- ❖ Low cost
- ❖ Operates on 12V
- ❖ Low current consumption
- ❖ Effective operation at over one hundred meters.
- ❖ Anti-covert surveillance beep during operation.
- ❖ Simple to install.

#### Description

The ELCOM is a lift communication system designed to allow two-way communication between the lift car and the machine room with the priority given to the engineer in the machine room over the passengers in the car.

The system consist of two parts:

1. Car unit.
2. Machine room unit (telephone).

#### **1. Car Unit**

The car unit is usually installed in the car behind the COP. The car unit allows the passengers a hand-free communication link to the engineer in the machine room in case of emergency or lift break down.

#### **2. Machine Room Unit**

The machine room unit is a simple intercom telephone with a press to talk (PTT) switch. The car unit and machine room unit are connected by a single three-core cable.

#### Communication Regime:

The engineer in the machine room has priority over passengers in the car. When the press to talk switch is pressed the car unit is switched to speaker only. Passengers cannot interrupt the engineer.

#### Anti-Covert Surveillance:

In order to avoid surveillance from the machine room an anti-surveillance beep is generated in the car as long as the machine room telephone is active so in car conversation cannot be monitored without passengers being aware.

#### Volume Control:

Volume control is provided for traffic in both directions, i.e. level of signal from machine room to car and vice versa can be adjusted by an on-board potentiometer (fig.3).

#### Control Lamp

The PCB has an on-board control lamp (fig.3). This lamp is lit each time the PTT switch on the telephone is pressed. This lamp is a useful tool during installation and troubleshooting.



**System Installation**

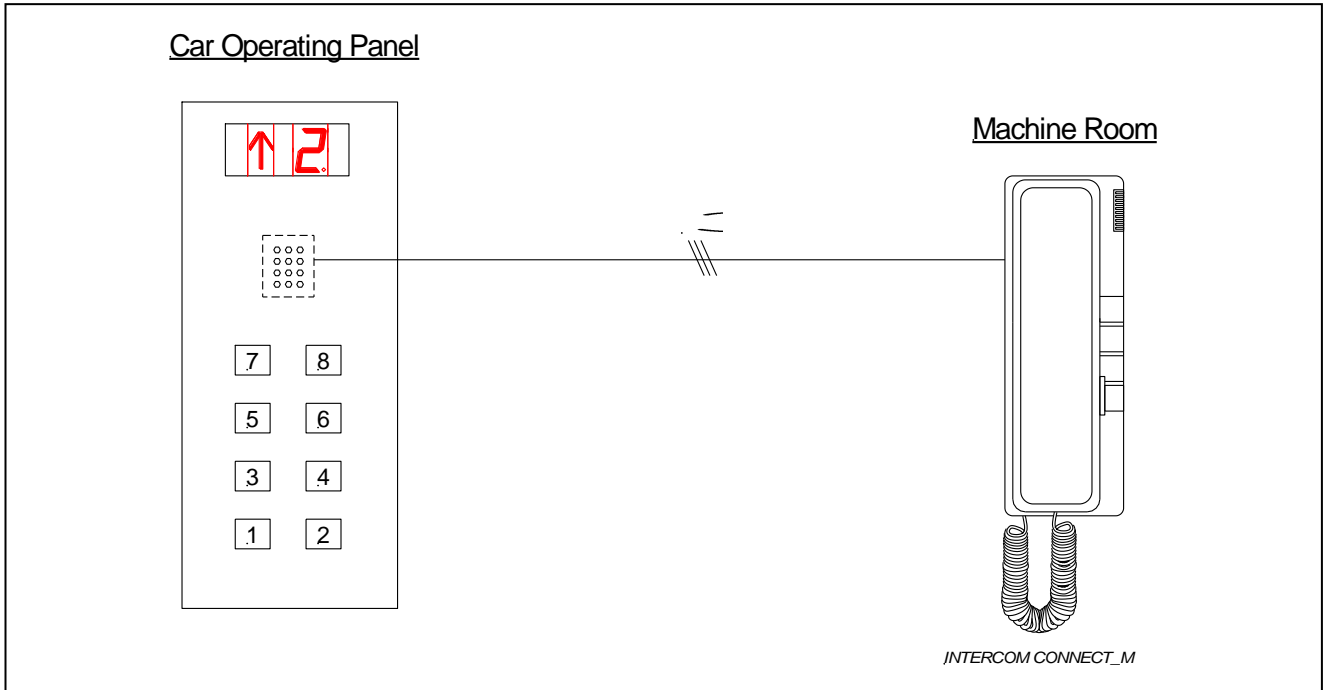

**Connection Diagram**

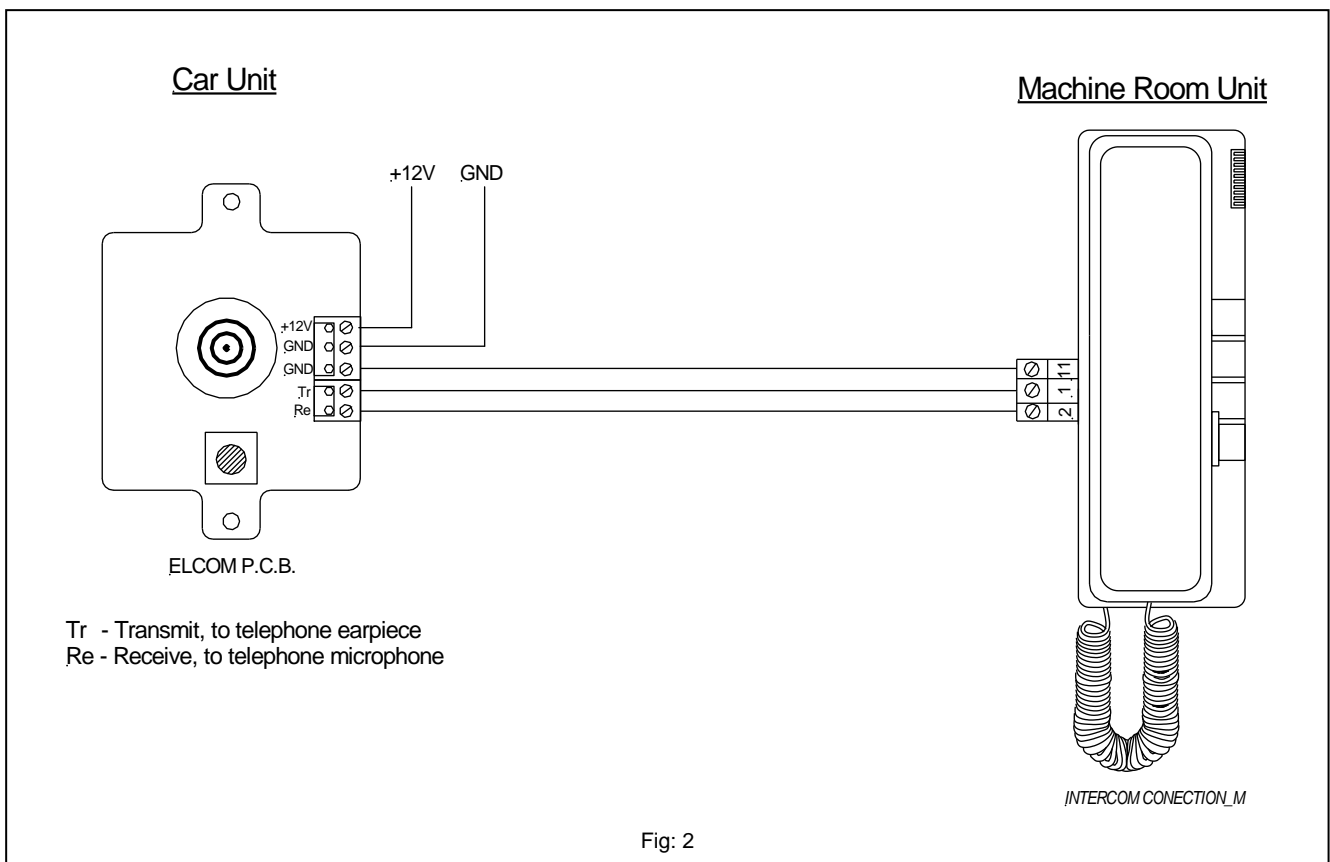

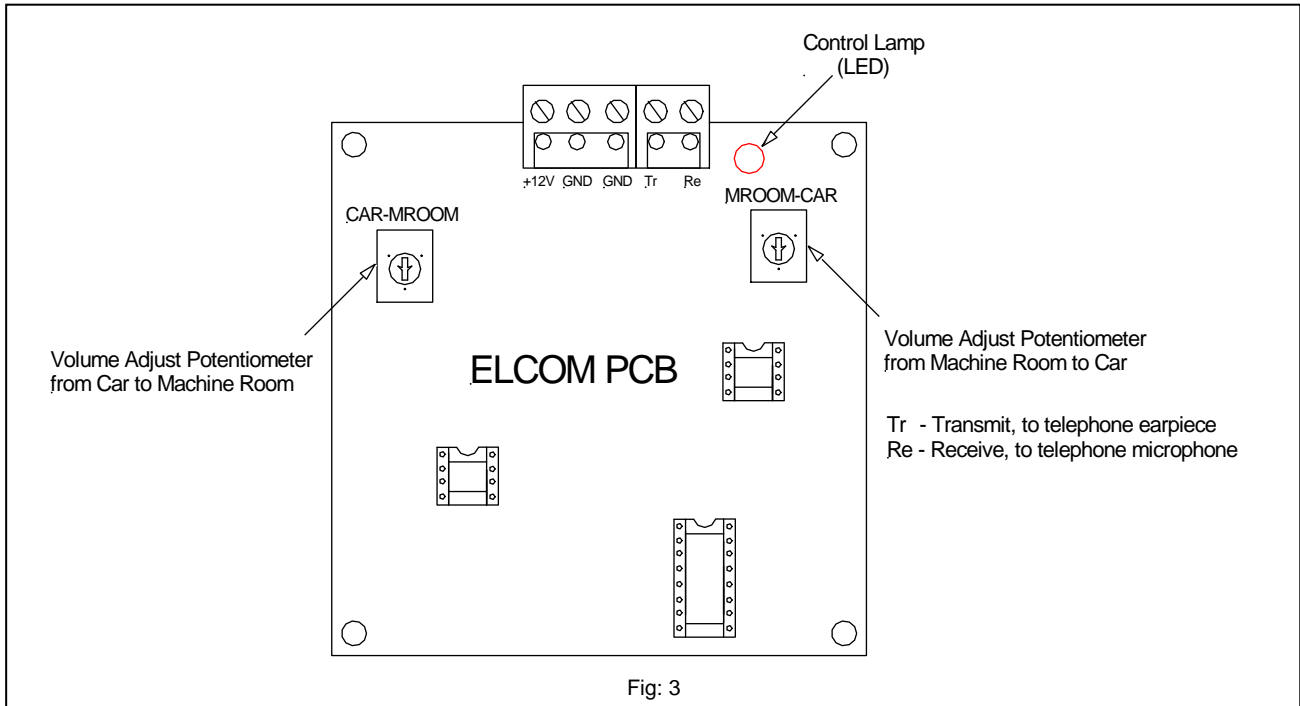
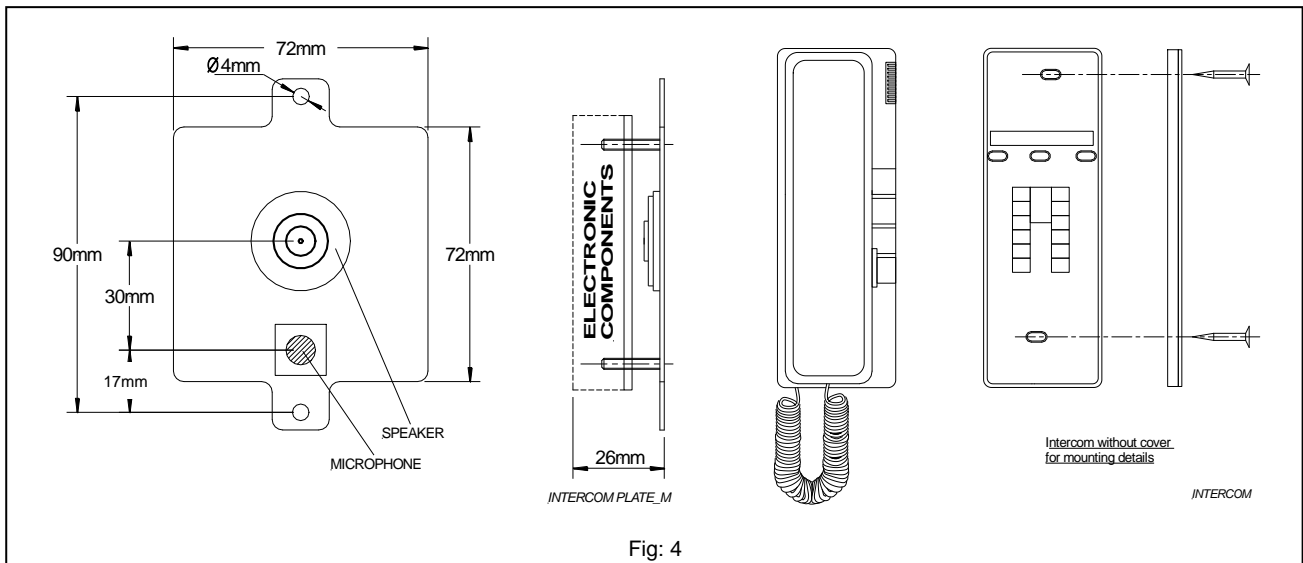
**ELCOM PCB Diagram****Mounting Details****Specifications**

Power input	12V DC.
Operating Distance	More than 100 m
Current Consumption	10 ma
Packed weight	450 gr.

**Ordering information**

Catalogue model code: ELCOM

Talinor (UK) Ltd. reserves the right to change specifications without notice.

Talinor en ELCOM ELCOM\_DS v1.01 .doc